

RUSKIN[®]
GO GREEN  *GO RUSKIN*

Commercial Air Doors

ACC and ACCEH Series



Ruskin Air Doors

Energy Saving Comfort

Clean Safe Surrounding

Flexible Color Selections



Ruskin ACC series doors protect against undesirable environments around door openings. They are designed to keep dirt, dust, fumes, insects, pollen and odors outside while maintaining a cleaner and healthier environment inside. Air Doors save energy and lower building operating costs while providing a comfortable environment for customers, visitors and employees. Ruskin Air Doors include an industry's best 5-Year warranty on the entire assembly.



Features

- UL Listed assembly
- Adjustable inlet and discharge airflow
- 5-year warranty on entire unit!
- 15 Standard Colors

Accessories & Options

- Custom Cabinet Color
- Ruskin Control Box — for Manual On/Off Control
- Door Switches — Plunger or Roller Type
- Air Filter — Reusable, Cleanable Aluminum Mesh



**5-Year
Warranty**

MODEL SELECTION CHART

		Size (inches)	Motor	Cabinet Color	Control Box	Door Switch	Filter (inches)
ACC		36	115V/1ph 208-240V/1ph 480V/3ph	Choose from 15 Standard Colors or Choose Custom Color	CB	P – Plunger R – Roller	F-XX
		42					
		48					
		64					
		78					
		84					

Suggested Air Door Specification — Ruskin Model: ACC Series

Furnish and install at the locations shown on the plans or in accordance with the schedules, commercial air doors that meet the following minimum requirements.

Commercial air door cabinet shall be minimum 20 gauge (0.9) thick painted galvanized steel. Discharge grille shall have adjustable blades made of 6063T5 aluminum and shall extend the full length of the discharge opening. The discharge grille shall be securely fastened by 24 gauge (0.6) stainless steel clips. Adjustable inlet grille shall be single deflection extruded aluminum with clear anodize finish.

Cabinet finish shall be baked enamel with minimum 50% Kynar finish. Colors shall be one of 15 Ruskin standard colors or as specified by the architect.

Motor and blower base shall be manufactured with minimum 16 gauge (1.6) galvanized steel. Motor shall be 115V/60Hz/1ph [or 208/240V/60Hz/1ph] [or 480V/60Hz/3ph]. The blower shall include forward curve (FC) double wide double inlet wheel (DWDI).

Optional control box shall be NEMA 1 and shipped loose and field mounted in a convenient location. Control box can

be used for standalone manual control or in conjunction with optional door switches.

Optional door switches shall be plunger operated [or roller operated]. On 480V/3ph units, the Ruskin control box shall be required if a door switch is selected.

Optional air filters shall be reusable and cleanable aluminum wire mesh.

Commercial air doors shall be:

- UL listed – UL 507
- Airflow tested in accordance with AMCA Standard 220
- Sound tested in accordance with ANSI S12.51

Commercial air doors shall carry a (5) five year warranty on the entire air door assembly. Air doors with parts-only warranty shall not be acceptable.

Air door submittals shall include door width, application, location, color, motor voltage, and variations. Commercial air doors shall in all respects be equivalent to Ruskin models ACC-36, ACC-42, ACC-48, ACC-64, ACC-78 or ACC-84.

Applications & Performance

Ruskin Air Doors are easy to install in a variety of locations; in restaurants, supermarkets, retail stores, convenience stores, educational institutes, hospitals, hotels, banks, theaters, laboratories, libraries, offices, freezers and manufacturing facilities.

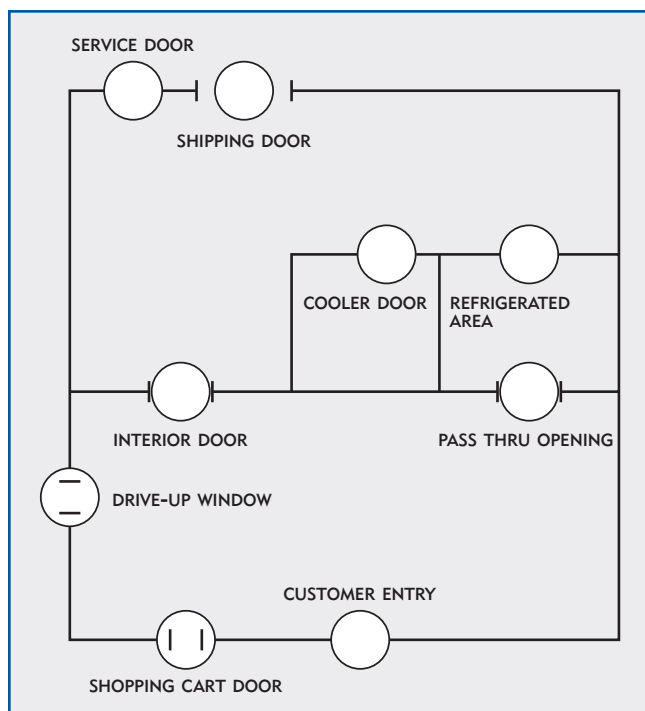

AIRFLOW & SOUND PERFORMANCE DATA

Model	Recommended Door Opening Width (in.)	Nozzle Opening (in.)	Motor (hp)	Amp Draw (115/208/480)	Airflow (cfm)	Unit Wt. (lbs)	Sound Power (dBA)
ACC-36	32" (813)	4" x 36"	1/2	5.1/2.5/0.8	1226	61	60
ACC-42	38" (965)	4" x 42"	1/2	5.1/2.5/0.8	1226	65	60
ACC-48	44" (1118)	4" x 48"	1/2	5.1/2.5/0.8	1226	68	60
ACC-64	60" (1524)	4" x 64"	(2) 1/2	10.2/5.0/1.6	2452	113	63
ACC-78	74" (1880)	4" x 78"	(2) 1/2	10.2/5.0/1.6	2452	122	63
ACC-84	80" (2032)	4" x 84"	(2) 1/2	10.2/5.0/1.6	2452	126	63

Airflow tested to AMCA Standard 220

Sound tested to ANSI S12.31

Ruskin ACCEH Series – Commercial Electric Heat Air Doors

Ruskin ACCEH air doors contain electric heaters and provide instantaneous comfort in cold weather situations. Available in many heater ranges, the ACCEH works well in any climate. Ruskin ACCEH heated air doors include a factory furnished and mounted control box with thermostat control. Ruskin Air Doors with electric heat include an industry's best 5-Year warranty on the entire assembly.



**5-Year
Warranty**

ELECTRIC HEAT — MODEL SELECTION CHART

	Size (inches)	Motor	Watts	Cabinet Color	Control Box	Door Switch	Filter (inches)
ACCEH	36	208-240V/1ph 480V/3ph	kW	Choose from 15 Standard Colors or Choose Custom Color	CB	P – Plunger R – Roller	F-XX
	42						
	48						
	64						
	78						
	84						

NOTE: In the case of wide door openings, units can be mounted side-by-side with own thermostat for individual control.

Suggested Electric Heat Air Door Specification — Ruskin Model ACCEH

Furnish and install at the locations shown on the plans or in accordance with the schedules, commercial air doors with electric heat that meet the following minimum requirements.

Commercial air door cabinet shall be minimum 20 gauge (0.9) thick painted galvanized steel. Discharge grille shall have adjustable blades made of 6063T5 aluminum and shall extend the full length of the discharge opening. The discharge grille shall be securely fastened by 24 gauge (0.6) stainless steel clips. Adjustable inlet grille shall be single deflection extruded aluminum with clear anodize finish.

Cabinet finish shall be baked enamel with minimum 50% Kynar finish. Colors shall be one of 15 Ruskin standard colors or as specified by the architect.

Air doors shall be provided with a factory furnished and mounted NEMA 1 control box, electric heating elements and thermostat. The control box is mounted on the right hand [left optional] side facing the inlet grille and shall control on/off/auto operation of the motor/blower assembly. The heater elements shall consist of wired heating coils located in the discharge and shall include a protective screen. Ruskin electric heated air doors shall include a 24 vac heating thermostat with system and fan switches. Thermostat shall be remote mounted for customer flexibility.

Motor and blower base shall be manufactured with minimum 16 gauge (1.6) galvanized steel. Motor shall be (specifier select) 208V/1ph/60hz multiple speed (or) 240V/1ph/60hz multiple speed (or) 480V/3ph/60hz single speed. The blower shall include forward curve (FC) double wide double inlet wheel (DWDI).

Optional door switches shall be (specifier select) plunger operated (or) roller operated.

Optional air filters shall be reusable and cleanable aluminum wire mesh.

Commercial air doors shall be:

- UL listed – UL 2021
- Canadian listed – CSA C22.2
- Airflow tested in accordance with AMCA Standard 220
- Sound tested in accordance with ANSI S12.51

Commercial air doors shall carry a (5) five year warranty on the entire air door assembly. Air doors with parts-only or less than 5 year warranty shall not be acceptable.

Air door submittals shall include door width, application, location, color, motor voltage, heater kW, and variations. Commercial electric heated air doors shall be in all respects equivalent to Ruskin models ACCEH-36, ACCEH-42, ACCEH-48, ACCEH-64, ACCEH-78 or ACCEH-84.



Accessories & Options (Electric Heat)

- Custom Cabinet Colors
- Door Switches — Plunger or Roller Type
- Air Filter — Reusable, Cleanable Aluminum Mesh
- Left Hand Control Box

MODEL – MOTORS, HEATERS AND CONTROL BOX DATA

Air Door Model	Supply Voltage	Heater Watts (kW)	Amps Total Unit	Control Box Location*	Slave Control Box	Unit Wt. (lbs)	Sound Power (dBA)
ACCEH-36	208V/60Hz/1ph	4.5, 6.8, 9	13,19,24	R (or L)	N/A	82	60
	240V/60Hz/1ph	6, 9, 12	15,21,27	R (or L)	N/A		
	480V/60Hz/3ph	8, 12, 16	10,15,20	R (or L)	N/A		
ACCEH-42	208V/60Hz/1ph	4.5, 6.8, 9	13,19,24	R (or L)	N/A	86	60
	240V/60Hz/1ph	6, 9, 12	15,21,27	R (or L)	N/A		
	480V/60Hz/3ph	8, 12, 16	10,15,20	R (or L)	N/A		
ACCEH-48	208V/60Hz/1ph	4.5, 6.8, 9	13,19,24	R (or L)	N/A	89	60
	240V/60Hz/1ph	6, 9, 12	15,21,27	R (or L)	N/A		
	480V/60Hz/3ph	8, 12, 16	10,15,20	R (or L)	N/A		
ACCEH-64	208V/60Hz/1ph	9	27	R (or L)	N/A	135	63
	208V/60Hz/1ph	13.6, 18	21,27	R (or L)	✓		
	240V/60Hz/1ph	12	30	R (or L)	N/A		
	240V/60Hz/1ph	18, 24	43,55	R (or L)	✓		
	480V/60Hz/3ph	16, 24	21,30	R (or L)	N/A		
	480V/60Hz/3ph	32	40	R (or L)	✓		
ACCEH-78	208V/60Hz/1ph	9	27	R (or L)	N/A	144	63
	208V/60Hz/1ph	13.6, 18	21,27	R (or L)	✓		
	240V/60Hz/1ph	12	30	R (or L)	N/A		
	240V/60Hz/1ph	18, 24	43,55	R (or L)	✓		
	480V/60Hz/3ph	16, 24	21,30	R (or L)	N/A		
	480V/60Hz/3ph	32	40	R (or L)	✓		
ACCEH-84	208V/60Hz/1ph	9	27	R (or L)	N/A	148	63
	208V/60Hz/1ph	13.6, 18	21,27	R (or L)	✓		
	240V/60Hz/1ph	12	30	R (or L)	N/A		
	240V/60Hz/1ph	18, 24	43,55	R (or L)	✓		
	480V/60Hz/3ph	16, 24	21,30	R (or L)	N/A		
	480V/60Hz/3ph	32	40	R (or L)	✓		

* The Ruskin control box comes factory mounted on the right side facing the inlet grille as standard

✓ Indicates that slave control box is required for proper operation. Slave control boxes ship loose.

Ruskin Air Door finish enhances the product appearance to blend with surrounding areas. Our finish provides excellent weathering resistance and flexibility for architects and engineers.

All Ruskin Air Doors receive a factory applied, baked-on color coating following thorough cleaning and pretreatment of metal.

Ruskin's High Performance Baked Enamel Finish is a 50% PVDF finish that provides fluoropolymer benefits such as long color life and resistance to chalking and chemicals.

Baked Enamel Coatings

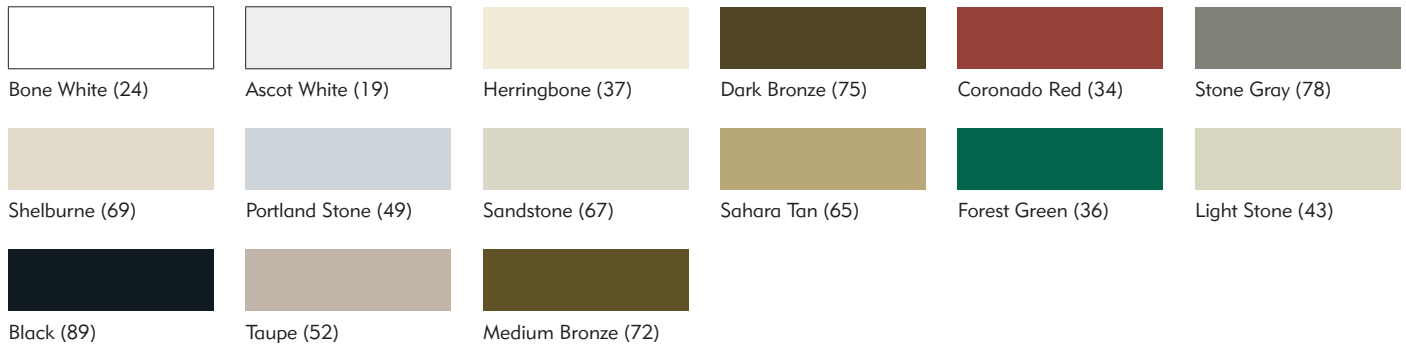

Ruskin can match colors in Kynar, Baked Enamel and Pearledize finishes. The colors shown herein are only a sample of the thousands of colors available. Please contact Ruskin for information regarding custom color matching.

RUSKIN[®]
Air & Sound Control
Specified by Many – Equaled by None

3900 Dr. Greaves Rd., Kansas City, MO 64030
 (816) 761-7476 ■ Fax (816) 765-8955
 Email: ruskin@ruskin.com ■ www.ruskin.com

RAD 08/09

